



JUMBO

GENERATORI D'ARIA CALDA A GRANDE PORTATA A COMBUSTIONE INDIRECTA
CON VENTILATORE ASSIALE

INDIRECT COMBUSTION HEAVY DUTY MOBILE SPACE HEATERS WITH AXIAL FAN



JUMBO - GENERATORI D'ARIA CALDA A GRANDE PORTATA A COMBUSTIONE INDIRETTA CON VENTILATORE ASSIALE

- Cassetto di copertura del bruciatore che consente la protezione da urti, polvere, acqua, eventi atmosferici e vasca di raccolta del gasolio/condensa
 - Bruciatore dotato di presa snorkel per garantire aria di combustione pulita mediante collegamento con guaina di aspirazione dall'esterno
 - Il nuovo scambiatore di calore abbinato ai nuovi ventilatori di maggiori prestazioni permettono di ottenere un rendimento termico del 92÷93%
 - Un migliore ancoraggio della struttura portante della macchina grazie a robuste staffe di fissaggio che ne consentono la movimentazione su qualunque superficie
 - Struttura portante con pannelli rimovibili per il lavaggio interno, anche a macchina appesa
 - Pannelli con pieghi di rinforzo a croce per garantire maggior rigidità e robustezza
 - Utilizzo esclusivamente di viti e inserti metrici per il fissaggio, no viti autofilettanti
 - Protezione di tutti gli elementi soggetti ad urti, eventi atmosferici etc.
 - Ventilatore protezione (IP 55):
 - rispondente alle direttive europee ERP 2009/125/CE target 2015;
 - molto silenzioso (rumore ≤ 67 db a 2 metri);
 - 7 pale: alte prestazioni (portata d'aria e pressione statica) per la diffusione omogenea dell'aria calda mediante guaina;
 - boccaglio ventilatore per convogliare l'aria e garantire alta pressione statica;
 - Quadro elettrico posteriore di comando (IP 65):
 - posizionato nella parte posteriore evita che sia a contatto con polvere, acqua, neve etc;
 - provvisto di una robusta copertura metallica che consente anche il ricovero di attrezzi e documenti;
 - Quadro elettrico anteriore di servizio (IP 65):
 - posizionato nella parte anteriore della macchina dentro il cassetto copertura bruciatore: per evitare che sia a contatto con polvere, acqua, neve per una più facile manutenzione; per un più agevole controllo ed intervento dell'operatore
 - Ciascun componente principale (ventilatore, bruciatore, termostati, etc.) è munito di connessioni rapide di collegamento elettrico:
 - velocità di montaggio/smontaggio e di intervento tecnico
 - eliminazione di errori di installazione/smontaggio
- *Burner cover: protects the burner against blows, dust, water, weather and collect diesel fuel/condensation recovery basin*
 - *Burner is supplied with snorkel jack to ensure clean air combustion through connection with outdoor air uptake duct*
 - *The new heat exchanger with the newly designed higher performance fans ensure heat efficiency of 92 ÷93%*
 - *Better anchorage to the machine's weight bearing structure through sturdy attachment rods which allow for movement on any floors*
 - *Bearing structure with removable panels for interior washing, also in hanging models*
 - *Panels with reinforcement cross pleats to ensure superior rigidity and strength*
 - *Exclusive use of metric screws and inserts for fastening, no self-tapping screws*
 - *Ventilator (IP 55):*
 - *in conformity with European directives ERP 2009/125/CE target 2015*
 - *very low noise fan (noise level ≤ 67 db at 2 meters)*
 - *7-blade fan with high performance (air flow and static pressure) for uniform diffusion of warm air through duct*
 - *fan outlet cone to convey air and ensure high static pressure*
 - *Control rear electrical panel (IP 65):*
 - *located at the top rear of the machine to avoid contact with dust, water, snow*
 - *supplied with a sturdy metal cover to prevent damage and unauthorized access; also handy for storage of tools, papers, etc;*
 - *Service front electrical panel:*
 - *located at the front of the machine inside the burner cover lid: to prevent contact with dust, water, snow; for easier maintenance; to facilitate controls and maintenance by the operator*
 - *Every main component (fan, burner, thermostats, etc.) is supplied with quick couplings of electrical connections IP68:*
 - *fast assembly, disassembly and technical maintenance*
 - *eliminates installation/disassembly mistakes*







*JUMBO - INDIRECT COMBUSTION HEAVY DUTY MOBILE SPACE HEATERS
WITH AXIAL FAN*

ACCESSORI A RICHIESTA / ACCESSORIES ON DEMAND

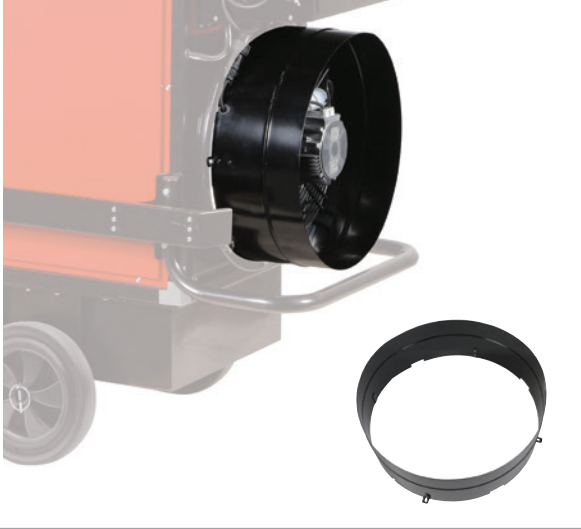
RACCORDO 1 VIA ONE WAY ADAPTER	RACCORDO 2 VIE TWO WAYS ADAPTER
 	 
<p>Mod. JUMBO 85 (Ø 450 mm) Cod. 02AC821</p>	<p>Mod. JUMBO 85 (Ø 400 mm) Cod. 02AC822</p>
<p>Mod. JUMBO 110 (Ø 500 mm) Cod. 02AC831</p>	<p>Mod. JUMBO 110 (Ø 400 mm) Cod. 02AC832</p>
<p>Mod. JUMBO 145 (Ø 600 mm) Cod. 02AC841</p>	<p>Mod. JUMBO 145 (Ø 500 mm) Cod. 02AC842</p>
<p>Mod. JUMBO 185 (Ø 650 mm) Cod. 02AC851</p>	<p>Mod. JUMBO 185 (Ø 500 mm) Cod. 02AC852</p>
<p>Mod. JUMBO 235 (Ø 700 mm) Cod. 02AC861</p>	<p>Mod. JUMBO 235 (Ø 600 mm) Cod. 02AC862</p>
RACCORDO 4 VIE FOUR WAYS ADAPTER	GUAINE FLESSIBILI IN PVC L= 6 m CON CINGHIA DI FISSAGGIO FLEXIBLE AIR DUCTS 6 m WITH CLIP
 	 
<p>Mod. JUMBO 145 (Ø 350 mm) Cod. 02AC843</p>	<p>Mod. Ø 350 mm Cod. 02AC563</p>
<p>Mod. JUMBO 185 (Ø 350 mm) Cod. 02AC853</p>	<p>Mod. Ø 400 mm Cod. 02AC564</p>
<p>Mod. JUMBO 235 (Ø 400 mm) Cod. 02AC863</p>	<p>Mod. Ø 450/500 mm Cod. 02AC566</p>
	<p>Mod. Ø 600 mm Cod. 02AC567</p>
	<p>Mod. Ø 650/700 mm Cod. 02AC568</p>

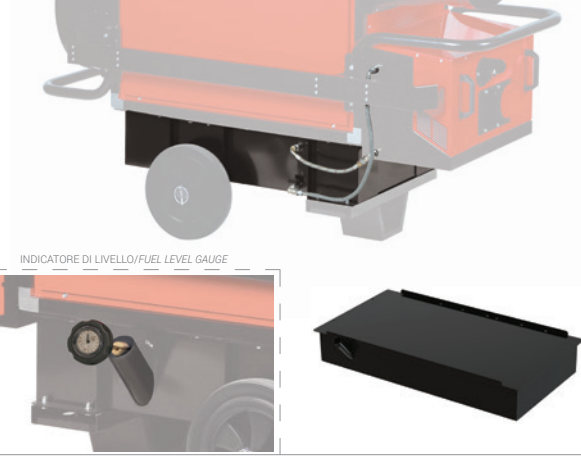
JUMBO - GENERATORI D'ARIA CALDA A GRANDE PORTATA A COMBUSTIONE INDIRETTA CON VENTILATORE ASSIALE

RACCORDO ASPIRAZIONE 1 VIA AIR INLET ADAPTER	GUAINA RINFORZATA PER RIPRESA ARIA REINFORCED FLEXIBLE AIR INLET DUCT
	
Mod. JUMBO 85 (Ø 505 mm) Cod. 02AC724	Mod. JUMBO 85 (Ø 510 mm, l=6m) Cod. 02AC795
Mod. JUMBO 110 (Ø 565 mm) Cod. 02AC734	Mod. JUMBO 110 (Ø 570 mm, l=6m) Cod. 02AC796
Mod. JUMBO 145-185 (Ø 625 mm) Cod. 02AC744	Mod. JUMBO 145-185 (Ø 650 mm, l=6m) Cod. 02AC797
Mod. JUMBO 235 (Ø 715 mm) Cod. 02AC764	Mod. JUMBO 235 (Ø 720 mm, l=6m) Cod. 02AC798
	Mod. Tutti/All Fascetta fissaggio guaina-clip for flexible duct (Ø 400-750 mm) Cod. 02AC663
KIT SERBATOIO TANK KIT	KIT PARAURTI LATERALE SIDE BUMPERS KIT
 <p>INDICATORE DI LIVELLO/FUEL LEVEL GAUGE</p>	
Mod. JUMBO 85 (litri/liters= 75) Cod. 02AC827	Mod. JUMBO 85 Cod. 02AC825
Mod. JUMBO 110 (litri/liters= 90) Cod. 02AC837	Mod. JUMBO 110 Cod. 02AC835
Mod. JUMBO 145 (litri/liters= 120) Cod. 02AC847	Mod. JUMBO 145 Cod. 02AC845
Mod. JUMBO 185 (litri/liters= 170) Cod. 02AC857	Mod. JUMBO 185 Cod. 02AC855
Mod. JUMBO 235 (litri/liters= 200) Cod. 02AC867	Mod. JUMBO 235 Cod. 02AC865
Mod. Indicatore di livello - Fuel level gauge Cod. 02AC510	

JUMBO - INDIRECT COMBUSTION HEAVY DUTY MOBILE SPACE HEATERS WITH AXIAL FAN













KIT STAFFE INFORCOLAMENTO LIFTING KIT	KIT RUOTE PIVOTTANTI SWIVELLING WHEELS KIT	BRUCIATORE GASOLIO ECOFLAM ECOFLAM DIESEL BURNER
		
Mod. JUMBO 85 Cod. 02AC826	Mod. JUMBO 85/110 (Ø 100 mm) Cod. 02AC815*	Mod. JUMBO 85 DIESEL/OIL Cod. 072B101
Mod. JUMBO 110 Cod. 02AC836		Mod. JUMBO 110 DIESEL/OIL Cod. 072B102
Mod. JUMBO 145 Cod. 02AC846		Mod. JUMBO 145 DIESEL/OIL Cod. 072B103
Mod. JUMBO 185 Cod. 02AC856		Mod. JUMBO 185 DIESEL/OIL Cod. 072B104
Mod. JUMBO 235 Cod. 02AC866		Mod. JUMBO 235 DIESEL/OIL Cod. 072B105
Mod. JUMBO 145/185/235 (Ø 150 mm) Cod. 02AC816*	Mod. JUMBO 85 DIESEL/OIL Cod. 076B101	Mod. JUMBO 145/185/235 (Ø 150 mm) Cod. 076B102
		Mod. JUMBO 110 DIESEL/OIL Cod. 076B102
		Mod. JUMBO 145 DIESEL/OIL Cod. 076B103
		Mod. JUMBO 185 DIESEL/OIL Cod. 076B104
		Mod. JUMBO 235 DIESEL/OIL Cod. 076B105
BRUCIATORE GASOLIO RIELLO RIELLO DIESEL BURNER	BRUCIATORE RIELLO GPL + RAMPA GAS LPG RIELLO BURNER + GAS TRAIN	BRUCIATORE RIELLO METANO + RAMPA GAS NATURAL GAS RIELLO BURNER + GAS TRAIN
		
Mod. JUMBO 85 DIESEL/OIL Cod. 076B101	Mod. JUMBO 85 GPL/LPG Cod. 074B101-04	Mod. JUMBO 85 METANO/NATURAL GAS Cod. 074B102-04
Mod. JUMBO 110 DIESEL/OIL Cod. 076B102	Mod. JUMBO 110 GPL/LPG Cod. 074B103-04	Mod. JUMBO 110 METANO/NATURAL GAS Cod. 074B104-04
Mod. JUMBO 145 DIESEL/OIL Cod. 076B103	Mod. JUMBO 145 GPL/LPG Cod. 074B103-05	Mod. JUMBO 145 METANO/NATURAL GAS Cod. 074B104-05
Mod. JUMBO 185 DIESEL/OIL Cod. 076B104	Mod. JUMBO 185 GPL/LPG Cod. 074B103-07	Mod. JUMBO 185 METANO/NATURAL GAS Cod. 074B104-07
Mod. JUMBO 235 DIESEL/OIL Cod. 076B105	Mod. JUMBO 235 GPL/LPG Cod. 074B105-08	Mod. JUMBO 235 METANO/NATURAL GAS Cod. 074B106-08
PASSAPARETE SNORKEL + GUAINA FLESSIBILE SNORKEL PASS PLATE + FLEXIBLE DUCT	KIT SERRANDA TAGLIAFUOCO MANDATA ARIA (REI 120) AIR OUTLET FIRE SHUTTER KIT (REI 120)	KIT SERRANDA TAGLIAFUOCO INGRESSO ARIA (REI 120) AIR INLET FIRE SHUTTER KIT (REI 120)
		
Mod. JUMBO 85/110/145/185 (Ø 100 mm) Cod. 02AC793	Mod. JUMBO 85 Cod. 02AC828	Mod. JUMBO 85 (Ø 505 mm) Cod. 02AC908**
Mod. Guaina/Duct (Ø 100 mm - l=5 m) Cod. 02AC577	Mod. JUMBO 110 Cod. 02AC838	Mod. JUMBO 110 (Ø 565 mm) Cod. 02AC909**
Mod. JUMBO 235 (Ø 150 mm) Cod. 02AC794	Mod. JUMBO 145 Cod. 02AC848	Mod. JUMBO 145-185 (Ø 625 mm) Cod. 02AC910**
Mod. Guaina/Duct (Ø 150 mm - l=5 m) Cod. 02AC792	Mod. JUMBO 185 Cod. 02AC858	Mod. JUMBO 235 (Ø 715 mm) Cod. 02AC911**
	Mod. JUMBO 235 Cod. 02AC868	

* Montabili solo in assenza di serbatoio installato - Only without tank



** Necessario abbinamento a "raccordo aspirazione" - Additionally it's necessary to buy "air inlet adapter"



JUMBO - GENERATORI D'ARIA CALDA A GRANDE PORTATA A COMBUSTIONE INDIRETTA CON VENTILATORE ASSIALE

<p>TERMOSTATO AMBIENTE +5/+30°C CON CAVO L=10 m E SPINA 90° <i>ROOM THERMOSTAT +5/+30°C CABLE 10 m, PLUG 90°</i></p> 	<p>TERMOSTATO AGRICOLTURA/CANTIERE -5/+50°C CON CAVO L=10 m E SPINA 90° <i>HEAVY DUTY THERM. -5/+50°C CABLE 10 m, PLUG 90°</i></p> 	<p>TERMOSTATO ELETTRONICO DI PRECISIONE IP55 CON DISPLAY -10/+70°C SENZA CAVO E SPINA <i>ELECTRONIC THERMOSTAT IP55 WITH DISPLAY -10/+70°C WITHOUT POWER CORD AND PLUG</i></p> 
<p>Cod. 02AC581</p>	<p>Cod. 02AC582</p>	<p>Cod. 02AC294</p>
<p>FILTRO GASOLIO RISCALDANTE <i>PRE-HEATED FUEL FILTER</i></p>	<p>KIT COLLEGAMENTO MONOTUBO CON FILTRO DE AERATORE <i>SINGLE PIPE EXTERNAL FUEL TANK CONNECTION KIT WITH DE AERATOR</i></p>	<p>FILTRO SEPARATORE ACQUA <i>ANTI-WATER FILTER</i></p>
		
<p>Cod. 02AC818</p>	<p>Cod. 02AC819</p>	<p>Cod. 02AC801</p>
<p>KIT COLLEGAMENTO BITUBO SERBATOIO ESTERNO GASOLIO (l= 5 m) + KIT ATTACCHI RAPIDI <i>TWO-PIPE EXTERNAL FUEL TANK CONNECTION KIT (l=5 m) + QUICK CONNECTIONS KIT</i></p>	<p>FILTRO GAS <i>GAS FILTER</i> (P.in MAX 2 bar)</p>	<p>FILTRO REGOLATORE GAS <i>GAS FILTER REGULATOR</i> (P.in MAX 2 bar)</p>
		
<p>Mod. Kit collegamento bitubo serbatoio esterno/ <i>Two-pipe external tank connection kit</i> Cod. 02AC668</p>	<p>Mod. JUMBO 85/110/145 (DN 25 - 1") Cod. 03AC603</p>	<p>Mod. JUMBO 85/110/145 GAS METANO - NATURAL GAS (DN 25 3/4" or 1") (P.out set. 20mbar) Cod. 03AC617</p>
<p>Mod. Kit attacchi rapidi (M+F x 2)/ <i>Quick connections kit (M+F x 2)</i> Cod. 02AC669</p>	<p>Mod. JUMBO 185/235 (DN 32 - 1 1/4") Cod. 03AC604</p>	<p>Mod. JUMBO 85/110/145 GPL - LPG (DN 25 3/4" or 1") (P.out set. 30mbar) Cod. 03AC618</p> <p>Mod. JUMBO 185/235 (DN 32 - 1 1/4") (P.out non settato - to be set) Cod. 03AC602</p>
<p>TUBO GAS MEDIA PRESSIONE (l= 3 m) + VAL- VOLA CHIUSURA + RACCORDI COLLEGAMENTO <i>MEDIUM PRESSURE GAS HOSE (l= 3 m) + GAS VALVE + CONNECTIONS</i> (P. MAX 10 bar)</p>	<p>TUBO GAS BASSA PRESSIONE (l= 2 m) + VALVOLA CHIUSURA + RACCORDI COLLEGAMENTO <i>LOW PRESSURE GAS HOSE (l= 2 m) + GAS VALVE + CONNECTIONS</i> (P.in MAX 0,5 bar)</p>	<p>TUBO SCARICO FUMI INOX L = 1 m <i>STAINLESS STEEL EXHAUST PIPE L = 1 m</i></p>
		
<p>Mod. JUMBO 85/110/145 Tubo/Hose gas 1" Cod. 03AC615</p>	<p>Mod. JUMBO 85/110/145 Tubo/Hose gas 1" Cod. 03AC612</p>	<p>Mod. JUMBO 85/110 (Ø 150 mm) Cod. 02AC285</p>
<p>Mod. JUMBO 185/235 Tubo/Hose gas 1 1/4" Cod. 03AC616</p>		<p>Mod. JUMBO 145/185/235 (Ø 200 mm) Cod. 02AC287</p>

JUMBO - INDIRECT COMBUSTION HEAVY DUTY MOBILE SPACE HEATERS WITH AXIAL FAN

TERMINALE PER CAMINO IN INOX STAINLESS STEEL CHIMNEY POT	KIT SUPPORTO SCARICO FUMI CHIMNEY SUPPORT KIT	KIT RICOVERO SCARICO FUMI CHIMNEY HOLDER KIT
		
Mod. JUMBO 85/110 (Ø 150 mm) Cod. 02AC657	Mod. JUMBO 85/110 Cod. 02AC813	Mod. JUMBO 85 Cod. 02AC824
		Mod. JUMBO 110 Cod. 02AC834
Mod. JUMBO 145/185/235 (Ø 200 mm) Cod. 02AC658	Mod. JUMBO 145/185/235 Cod. 02AC814	Mod. JUMBO 145 Cod. 02AC844
		Mod. JUMBO 185 Cod. 02AC854
		Mod. JUMBO 235 Cod. 02AC864

Quadro elettrico posteriore- Rear electrical panel

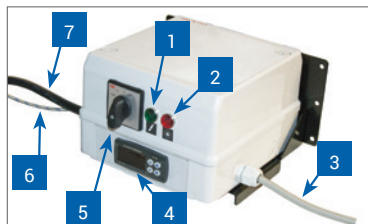

Legenda

- 1 Alimentazione elettrica
- 2 Surriscaldamento motore (solo per trifase)
- 3 Cavo motore
- 4 Termoregolatore che consente:
 - il settaggio del termostato FAN per il controllo ventilatore: pre riscaldamento e post ventilazione camera di combustione
 - il settaggio termostati LIMIT per il controllo del bruciatore
 - la visualizzazione delle ore di funzionamento macchina
 - la temperatura uscita aria dalla mandata
 - modifiche settaggio tramite password
- 5 Interruttore 4 posizioni:
 - O**= STOP
 - V**= VENTILAZIONE (ARIA FRESCA)
 - H**= RISCALDAMENTO
 - H+V**= RISCALDAMENTO CON VENTILAZIONE CONTINUA
- 6 Sonda termoregolatore
- 7 Cavo alimentazione

Legend

- 1 Electrical power supply
- 2 Motor overheat (only for three-phase)
- 3 Motor cable
- 4 Thermoregulator allows for:
 - FAN thermostat setting to control the fan: before heating and after ventilation of combustion chamber
 - LIMIT thermostat setting for burner control
 - display of machine's hours of work
 - temperature of air exiting the outlet
 - setting changes with password
- 5 Switch 4 positions:
 - O**= STOP
 - V**= VENTILATION (FRESH AIR)
 - H**= HEATING
 - H+V**= HEATING WITH CONTINUOUS VENTILATION
- 6 Heat adjustment probe
- 7 Power cable

Quadro elettrico anteriore di controllo- Service front electrical panel

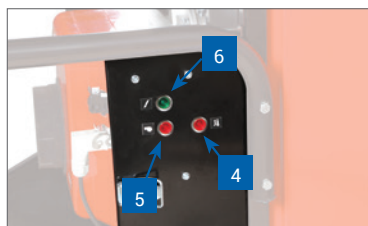
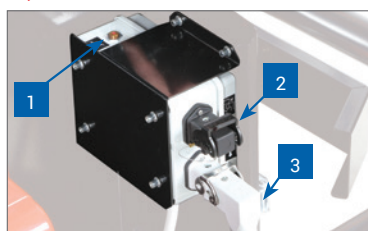

Legenda

- 1 OVERHEATING: termostato di sicurezza in caso di surriscaldamento con riarmo manuale
- 2 Presa filtro preriscaldamento
- 3 Presa termostato ambiente/umidostato/timer
- 4 Spia surriscaldamento termostati (overheating limit)
- 5 Spia bruciatore
- 6 Spia alimentazione elettrica

Legend

- 1 OVERHEATING: safety thermostat in case of overheating, with manual reset
- 2 Pre-heating filter socket
- 3 Socket for thermostat ambient/humidistat/timer
- 4 Thermostat overheat indicator light (overheating)
- 5 Burner indicator light
- 6 Electric power indicator light

JUMBO - GENERATORI D'ARIA CALDA A GRANDE PORTATA A COMBUSTIONE INDIRETTA CON VENTILATORE ASSIALE

INDIRECT COMBUSTION HEAVY DUTY MOBILE SPACE HEATERS WITH AXIAL FAN

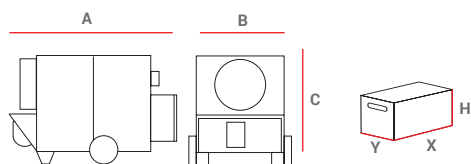

PESI E DIMENSIONI MACCHINA * WEIGHTS AND DIMENSIONS MACHINE					IMBALLO PACKAGING			
MOD	A	B	C	Netto/Net	X	Y	H	Lordo/Gross
	[mm]	[mm]	[mm]	[kg]	[mm]	[mm]	[mm]	[kg]
JUMBO 85	1.648	770	1.133	172	1.600	680	1.135	192
JUMBO 110	1.765	800	1.214	200	1.775	710	1.240	220
JUMBO 145	1.905	890	1.354	254	1.870	780	1.330	274
JUMBO 185	2.013	912	1.414	270	1.980	800	1.390	290
JUMBO 235	2.245	982	1.584	351	2.220	880	1.560	371

* Macchina completa con bruciatore e uscita 1 via
Complete machine with burner and one way adapter

MODELLO MODEL	CODICE CODE	MONOFASE / SINGLE PHASE					TRIFASE / THREE PHASE	
		JUMBO 85M * (OIL-GAS)	JUMBO 110M * (OIL-GAS)	JUMBO 145M * (OIL-GAS)	JUMBO 185M * (OIL-GAS)	JUMBO 235M * (OIL-GAS)	JUMBO 185T * (OIL-GAS)	JUMBO 235T * (OIL-GAS)
POTENZA TERM. NOMINALE RATED HEAT POWER	Hs [kW] Hs [kcal/h - BTU/h]	85,62 73.630 294.518	110,46 94.999 379.996	144,72 124.455 497.821	185,54 159.563 638.254	235,72 202.715 810.861	185,54 159.563 638.254	235,72 202.715 810.861
POTENZA TERMICA RESA OUTPUT HEAT POWER	Hs [kW] Hs [kcal/h - BTU/h]	79,37 68.255 273.019	102,51 88.159 352.636	134,87 115.992 463.969	171,07 147.117 588.470	216,86 186.498 745.992	171,07 147.117 588.470	216,86 186.498 745.992
RENDIMENTO EFFICIENCY	[%]	92,70	92,80	93,20	92,20	92,00	92,20	92,00
PORTATA D'ARIA AIR FLOW	[m³/h]	7.200	9.000	12.000	13.000	17.000	13.000	17.000
PRESS. STATICA DISP. AVAILABLE STATIC PRESS	[Pa- mm H ₂ O]	200 - 20	200 - 20	200 - 20	200 - 20	200 - 20	200 - 20	200 - 20
SALTO TERMICO TEMPERATURE RISE	a 20°C [°C]	47	49	48	57	55	57	55
CAMPO DI LAVORO EFFETTIVO EFFECTIVE HEAT RANGE	[m]	45	47	46	54	60	54	60
CONSUMO GASOLIO OIL CONSUMPTION	[kg/h]	6,77	8,74	11,45	14,68	18,65	14,68	18,65
CONSUMO METANO NATURAL GAS CONSUMPTION G20	[m³/h]	7,935	10,433	13,664	17,383	22,095	17,383	22,095
PRESSIONE ALIM. INLET PRESSURE G20	[mbar]	20	20	20	20	20	20	20
CONSUMO GPL LPG CONSUMPTION G31	[m³/h - kg/h]	3,127 - 6,10	4,191 - 8,07	5,436 - 10,53	6,976 - 13,59	8,819 - 17,17	6,976 - 13,59	8,819 - 17,17
PRESSIONE ALIM. INLET PRESSURE G31	[mbar]	37	37	37	37	37	37	37
ALIMENTAZIONE ELETTRICA ELECTRICAL POWER	[V - ph - Hz]	230 - 1 - 50	230 - 1 - 50	230 - 1 - 50	230 - 1 - 50	230 - 1 - 50	400-3-50 (230-3-50)◆	400-3-50 (230-3-50)◆
POTENZA ELETTRICA POWER CONSUMPTION	[W]	700	1.100	1570	1550	2550	1550	2550
Ø CAMINO Ø FLUE	[mm]	150	150	200	200	200	200	200
Ø GUAINA USCITA ARIA / L. MAX. Ø OUTLET HOSE / L. MAX	[mm/m] 1 VIA	500 - 25	500 - 25	600 - 25	700 - 25	700 - 30	700 - 25	700 - 30
	[mm/m] 2 VIE	400 - 15	400 - 15	500 - 15	500 - 15	600 - 15	500 - 15	600 - 15
	[mm/m] 4 VIE	-	-	350 - 15	350 - 15	400 - 15	350 - 15	400 - 15
Ø GUAINA SNORKEL / L. MAX. Ø OUTLET SNORKEL / L. MAX	[mm/m]	100 - 5	100 - 5	100 - 5	100 - 5	100 - 5	100 - 5	100 - 5
Ø GUAINA RIPRESA ARIA / L. MAX. Ø INLET HOSE / L. MAX	[mm/m]	510 - 6	570 - 6	650 - 6	650 - 6	720 - 6	650 - 6	720 - 6

* Macchina senza bruciatore ed uscita aria - Machine without burner and air adapter

◆Disponibile su richiesta - Available on demand